

OVERHEAD TUBE SUPPORT, VERTICAL ASSIST

FOCAL SPOT MOTION

Vertical travel..... 61.8 inches [1570mm]

Longitudinal travel..... 87.57 inch [2224mm] Minimum - UP TO - 191.57 inch [4866mm]
Maximum

Transverse travel 35.4 inch [900mm] Minimum UP TO 92.5 inch [2351mm]
Maximum

Tube angulation ±130 degrees

Column rotation..... ±180 degrees

Distance between Long Rails: 56.37 inches [1437mm] (+0.2 / -0.6")

TUBE MOUNTING..... 6 inch dia. fixed trunnion mount standard, 6-3/4 inch dia. optional

ELECTRICAL..... 120 VAC, 3 Amps continuous (or 240VAC, 1.6 amps) 50 / 60 Hz

MOUNTING..... Uni-Strut type ceiling mount with 1000 lb [455 kg] minimum load rating required. (Not included)

CONTROLS..... LCD Display for Table Receptor SID, Table Top SID and Tube Roll Angle, Longit SID to wallstand.
Control buttons for Transverse Locks, Vertical Locks, Longitudinal Locks, and All Locks.

SHIPPING INFORMATION

SHIPPING CRATE	DIMENSIONS			WEIGHT	
	Length	Width	Height	GROSS	NET (UNCRATED)
Main Crate	1480 mm (58.2")	775 mm (30.5")	995 mm (39.1")	264 kg (582 lb)	230 kg (507 lb)
Auxiliary Crate	1065 mm (41.9")	615 mm (24.2")	730 mm (28.7")	108 kg (238.1 lb)	80 kg (176.4 lb)
Large Longitudinal Rails & Transversal Rails	6200 mm (244.1")	280 mm (11")	350 mm (13.8")	120 kg (264.5 lb)	85 kg (187.4 lb)
Medium Longitudinal Rails & Transversal Rails	4850 mm (190.9")	280 mm (11")	350 mm (13.8")	100 kg (220.5 lb)	65 kg (143.3 lb)

(Specifications subject to revision)

OVERHEAD TUBE SUPPORT, VERTICAL ASSIST

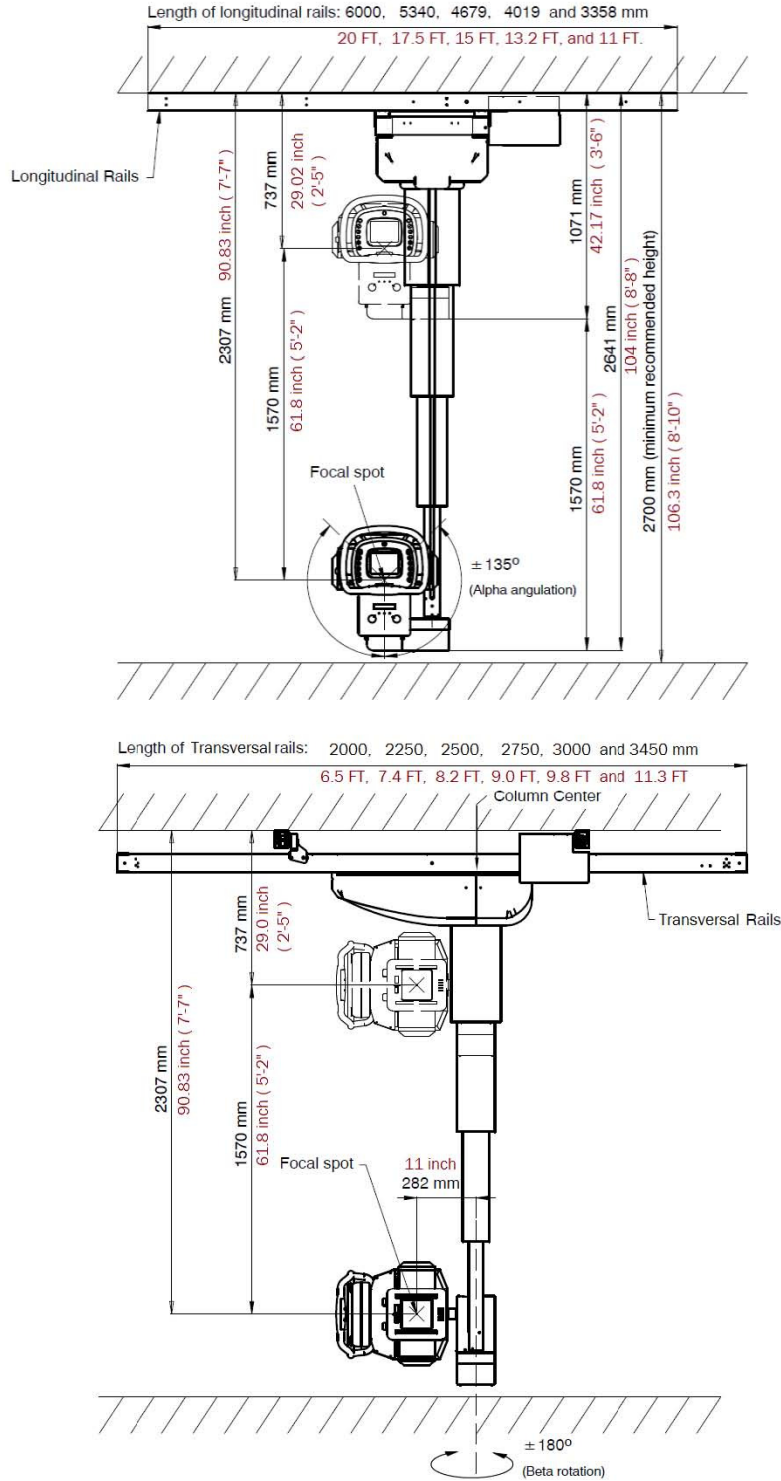

OVERHEAD TUBE SUPPORT, VERTICAL ASSIST

Rail Mounting Specifications

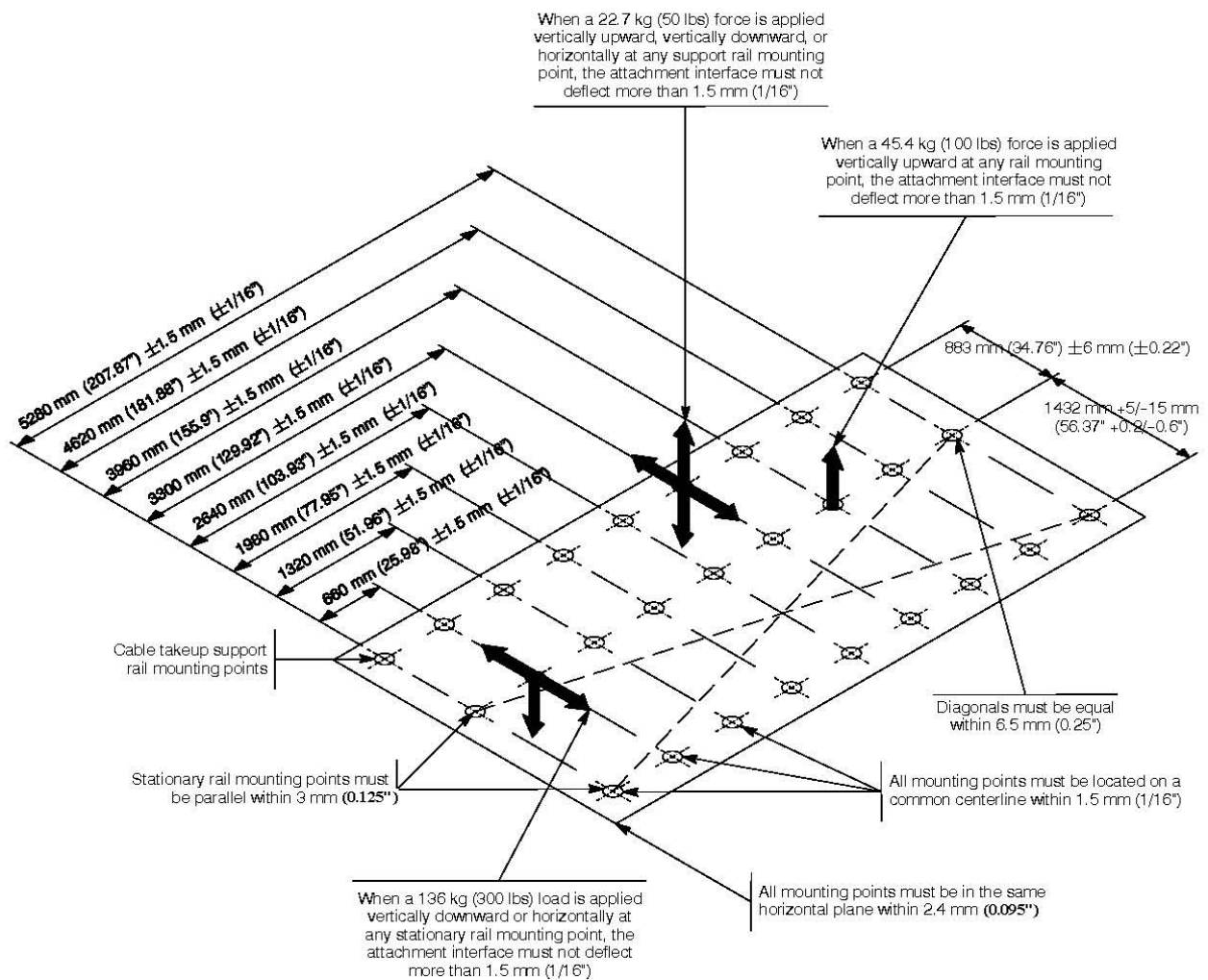

For more complete equipment details, refer to the PRE-INSTALL section of the service manual.